

OMNIVENT

Model: OV
Universal All-Position Vent Set
SWSI Belt Drive

CERTIFIED RATINGS



Omnivent Fans

PennBarry certifies that the Omnivent Fans shown herein are licensed to bear the AMCA Seal. The ratings shown are based on tests and procedures performed in accordance with AMCA Publication 211 and comply with the requirements of the AMCA Certified Ratings Program.

FANSIZER®

Product Selection Software

FanSizer software allows you to select the best centrifugal or axial unit for your application. Input CFM and static pressure, and FanSizer will make the optimum selection. It allows you to complete job schedules which you can store, modify and print in seconds. Features include: on-line help, on-screen product drawings and dimensions, and complete text specifications. In addition, you can convert job schedules to ASCII code for use with other programs like word processing.

FANCAD®

Library of CAD Drawings

FanCad is a library of drawings for use with computer-aided design (CAD) systems. FanCad's pre-drawn details can save hours of drafting time. Included are all popular PennBarry fans and related items.

Visit Our Web Site

Point your internet web browser to www.PennBarry.com for up-to-the-minute information including:

- On-line catalog
- List of nearest PennBarry representatives
- What's New
- HVAC "Hot Links"

FanSizer and FanCad are registered trademarks.

Table of Contents

Introduction	1
General Information	2
Features and Benefits	3
Options and Accessories	4
Motor Location Chart	6
Performance Data	7
Vent Set Dimensions	15
Sample Specifications	16
Limited Warranty	17

©2005 PennBarry™ All rights reserved.

Following publication of this catalog changes may have been made in standard equipment, options and the like that would not be included.

We reserve the right to make changes at any time, without notice, to models, specifications, options, availability, etc.

This bulletin illustrates the appearance of PennBarry products at the time of publication and we reserve the right to make changes in design and construction at anytime without notice. Your local sales representative is the best source for current information.

General Information

Omnivent - OV

The Use of the OV is Only Limited by Your Imagination.

The compact unitized design of the OV allows the fan to be mounted in a variety of ways not practical with other vent set designs. The fan can be suspended from the ceiling in a horizontal or vertical position; mounted directly to either interior or exterior wall; or integrated into machinery. The versatility of the OV provides simple solutions to many ventilation problems.

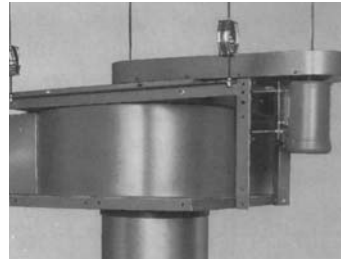

Suspended Mounting

The unitized design of the OV allows the fan to be easily suspended in the ceiling area in either a horizontal or vertical position. Since the OV can be mounted in any position, the need for elaborate duct-work can be minimized, thus reducing the pressure losses by eliminating elbows and other fittings.

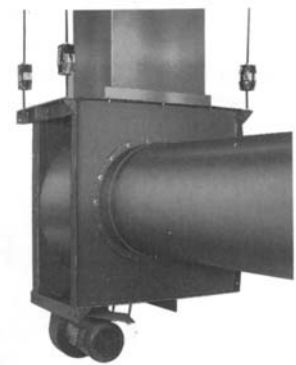

Universal Motor Location

The OV universal motor mount allows the motor to be mounted in up to six (6) different positions on the fan to fit your particular requirement for space. The OV universal belt guard can be used with any of the motor locations. Up to four motor mounting positions can be used with the optional weather cover.

Ideal for Contaminated Air Streams

The removable rotor feature coupled with the OV single thickness flat backward inclined bladed wheel lends itself to applications where ease of wheel removal for periodic cleaning is highly desirable. Some application examples are paint spray booth exhaust, lab hood exhaust, kitchen exhaust, etc.

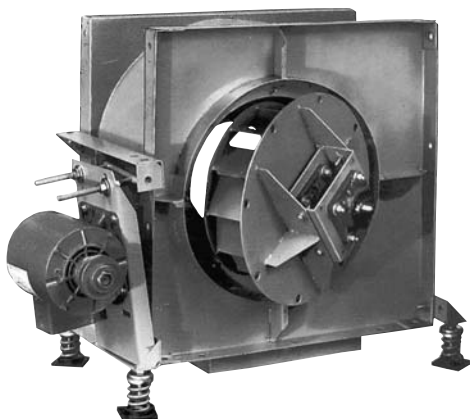

Wall Mount

The OV's unique design permits the fan to be mounted on an outside wall, thus solving a problem often encountered in multi-story buildings where duct-work cannot be run to the roof internally. A simple angle frame mounted to the building wall is all that is required to mount the OV. The fan can discharge horizontally with the discharge hood, and can discharge vertically with duct work extended above the roof level. The Vertical Discharge Cap can be mounted at the end of the duct for complete weather protection.

Extended Stack

Local and national codes often require a specific fan discharge height above the roof. With the OV this can easily be accomplished by adding an extended stack on the fan discharge. A vertical discharge cap can be mounted on the top of the stack to prevent weather and back draft problems.

Installation Flexibility

The center discharge housing design has a fixed scroll rotation, which creates a "universal" discharge rotation capability.

Wide Variety of Motor Arrangements

Six (6) motor arrangements are available to help the designer and installer facilitate many different field modification requirements.

Fast and Easy Connections

Existing duct-work connections are made faster and easier with standard horizontal or vertical mounting positions

Space-saving Design

Adds the flexibility needed to select a fan that can fit the most rigorous requirements in unique applications.

Easy to Maintain

The hinged rotor assembly provides easy access to the wheel and bearings for routine service. Ideal for contaminated air stream applications like paint booth exhaust, lab hood exhaust and kitchen exhaust.

Discharge Flexibility

Horizontal Discharge

The OV can be used for either right or left hand horizontal discharge because of its unique centered discharge. The wall-mount installation shown includes an accessory weather cover and PennBarry's exclusive discharge rain hood/back draft damper combination.

Vertical Discharge

The OV, when used for vertical discharge, can have the motor located on either the right or left hand side. Another unique wall-mount installation configuration is equipped with our exclusive vertical discharge damper assembly, which provides simple weather protection for the fan and prevents back drafts in the system.

Down Discharge

The OV unique design allows for down discharge without special modification. The motor can be located on either the right, or left hand side when used with weather cover.

Inlet Vanes

Inlet guide vanes for modulating air-flow are available on sizes 016 and larger. External vane assemblies are mounted to the inlet on sizes 016 to 022. Sizes 024 to 036 have inlet vanes nested in the spun inlet cone. Vane assemblies are furnished with an operator arm suitable for attachment to an operator. Pneumatic, hydraulic, and manual operators are available as an option. Inlet vanes have a pressure loss which must be inclined in the static pressure requirement for selection of the fan size and speed.

Drain

IPS threaded drain connections can be provided, located at the lowest point of the housing. Because of the low clearance of the housing above the mounting base, the fan may need to be elevated sufficiently to allow connection of a drain pipe. Drain plugs are not included.

Outlet Control Damper

Outlet volume control dampers are available to control the flow volume. Dampers are available with either parallel or opposed blade design. The damper can be mounted to the fan discharge; however to minimize damper loss and to provide better control, it is recommended that dampers be located in the duct work a minimum of 2 or 3 duct diameters downstream from the fan discharge.

Shaft Seal

Minimum leakage shaft seals can be factory mounted. Seal is of self-lubricating Teflon material, which protects the bearings from corrosive fumes.

Access Door

A gasketed access door can be provided for access to the wheel and housing. The access door is provided with nut and pawl hold-downs for quick opening. Location of the door should be specified relative to the discharge and motor position.

Inlet and Outlet Screens

Galvanized 1/2-inch mesh steel screens can be provided to protect the inlet or outlet when not connected to duct-work.

Special Coatings

A wide range of special paints and coatings are available for protection against corrosive substances and moisture. Refer to factory for information on resistance of the special coatings to various conditions.

AMCA B and C Spark Resistant Construction

OV's are available in AMCA Class B and C spark resistant construction when specified. The user is required to electrically ground all fan parts. The proper designators for spark resistant fans are indicated here. These definitions are as outlined in AMCA Standard 99-0401-82.

Type B - The fan shall have an entirely non-ferrous wheel and entirely non-ferrous ring about the opening through which the shaft passes.

Type C - The fan will be so constructed that a shift of the wheel or shaft will not permit two ferrous parts of the fan to rub or strike.

Note: Bearings shall not be placed in the air or gas stream.

Inlet and Outlet Flange

Outlet flanges are an integral part of the OV assembly. Inlet flanges are an available option. Flanges are fabricated of heavy gage steel and provided with holes for attachment of duct flanges. Companion flanges to match the flanges on the fan are also available.

Options and Accessories

Omnivent - OV

Vertical Discharge Cap and Damper

The vertical discharge cap and damper assembly is matched to the OV to provide weather protection and elimination of back drafts with minimum pressure loss. The aluminum gravity dampers are hinged with oversized pins pivoting in bronzed bearings for long trouble free life. The heavy gage wind band protects the dampers from wind shear. The discard cap is designed to drain rain away from the fan discharge. For applications requiring discharge heights greater than provided when the discharge cap is mounted directly to the fan, an extension duct is available to extend the discharge height up to 7 feet above the roof level.

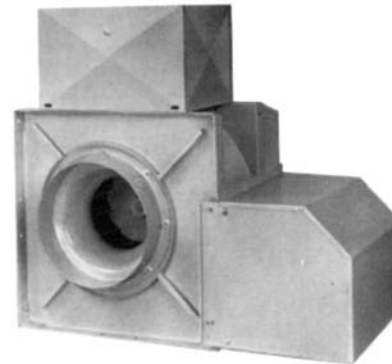
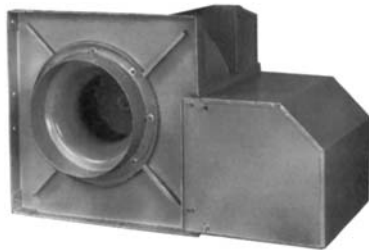

Weather Cover

Complete motor and drive protection is provided by the OV weather cover. The cover will accommodate up to six (6) motor mounting positions (depending on discharge position). The motor cover can be removed independently for easy access to the motor for electrical connections and belt tension adjustment.

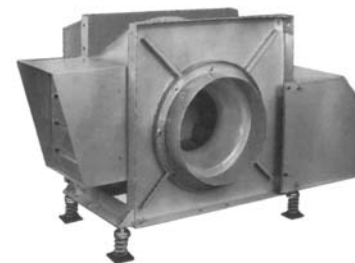

Horizontal Discharge Hood and Damper

The discharge hood and back draft damper assembly is matched to the OV to provide weather protection and elimination of back drafts with minimum pressure loss. The gravity damper is of aluminum construction with Zytel bearings for years of trouble free service.

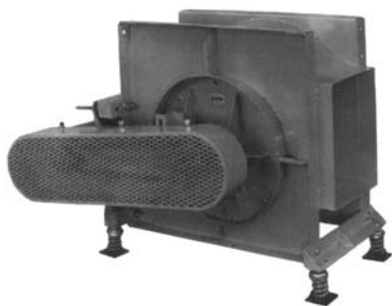

Belt Guard

Heavy-duty belt guard with expanded metal front is available. The guard will accommodate all six (6) motor positions with easy access when required. Belt tension can be adjusted without opening or removing the guard. Completely enclosed guards are available when required.

Vibration Isolators

Rubber-in-shear and spring isolators matched to the fan size and weight are available for both floor or suspended mounting. Convenient mounting rails are provided as part of the vibration isolation package. Rubber-in-shear isolators are recommended for sizes 016 and smaller.

Inlet Vanes

Inlet guide vanes for modulating air-flow are available on sizes 016 and larger. External vane assemblies are mounted to the inlet on sizes 016 to 022. Sizes 024 to 036 have inlet vanes nested in the spun inlet cone. Vane assemblies are furnished with an operator arm suitable for attachment to an operator. Pneumatic, hydraulic, and manual operators are available as an option. Inlet vanes have a pressure loss which must be included in the static pressure requirement for selection of the fan size and speed.

Drain

IPS threaded drain connections can be provided, located at the lowest point of the housing. Because of the low clearance of the housing above the mounting base, the fan may need to be elevated sufficiently to allow connection of a drain pipe. Drain plugs are not included.

Outlet Control Damper

Outlet volume control dampers are available to control the flow volume. Dampers are available with either parallel or opposed blade design. The damper can be mounted to the fan discharge; however to minimize damper loss and to provide better control, it is recommended that dampers be located in the duct work a minimum of 2 or 3 duct diameters downstream from the fan discharge.

Shaft Seal

Minimum leakage shaft seals can be factory mounted. Seal is of self-lubricating Teflon material, which protects the bearings from corrosive fumes.

Access Door

A gasketed access door can be provided for access to the wheel and housing. The access door is provided with nut and pawl hold-downs for quick opening. Location of the door should be specified relative to the discharge and motor position.



Inlet and Outlet Screens

Galvanized 1/2-inch mesh steel screens can be provided to protect the inlet or outlet when not connected to duct-work.

Special Coatings

A wide range of special paints and coatings are available for protection against corrosive substances and moisture. Refer to factory for information on resistance of the special coatings to various conditions.

AMCA B and C Spark Resistant Construction

OV's are available in AMCA Class B and C spark resistant construction when specified. The user is required to electrically ground all fan parts. The proper designators for spark resistant fans are indicated here. These definitions are as outlined in AMCA Standard 99-0401-82.

Type B - The fan shall have an entirely non-ferrous wheel and entirely non-ferrous ring about the opening through which the shaft passes.

Type C - The fan will be so constructed that a shift of the wheel or shaft will not permit two ferrous parts of the fan to rub or strike.

Note: Bearings shall not be placed in the air or gas stream.

Inlet and Outlet Flange

Outlet flanges are an integral part of the OV assembly. Inlet flanges are an available option. Flanges are fabricated of heavy gage steel and provided with holes for attachment of duct flanges. Companion flanges to match the flanges on the fan are also available.

Discharge Position and Motor Location Chart

Omnivent - OV

Base Mount with Weather Cover

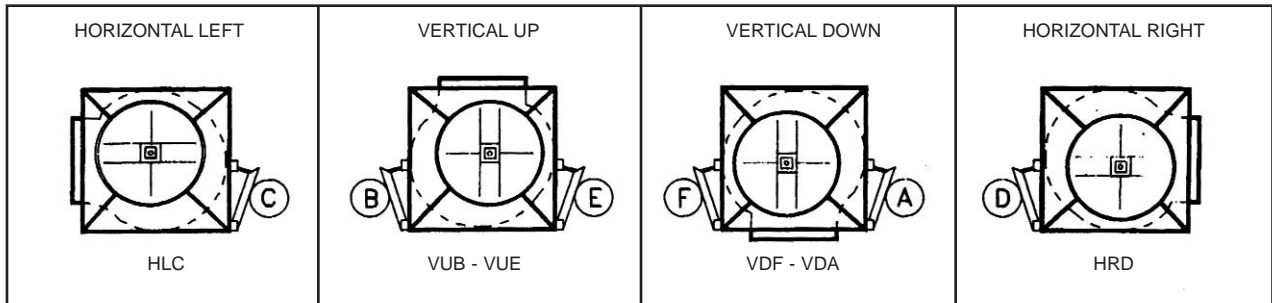

Base Mount With Weather Cover

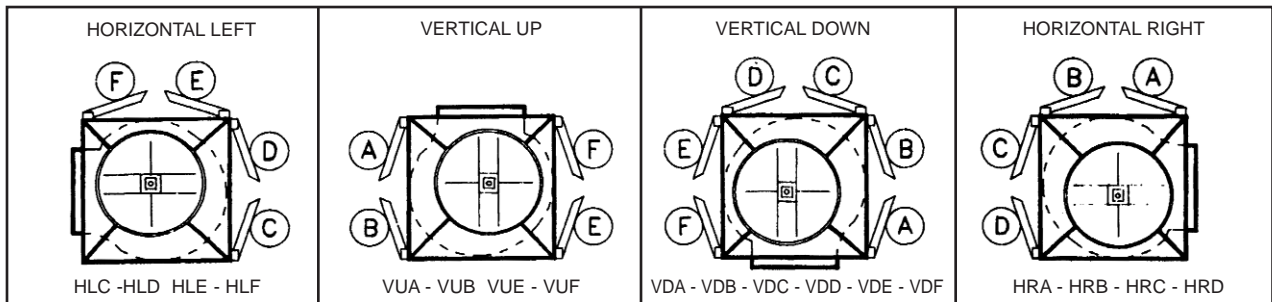

Vertically Suspended

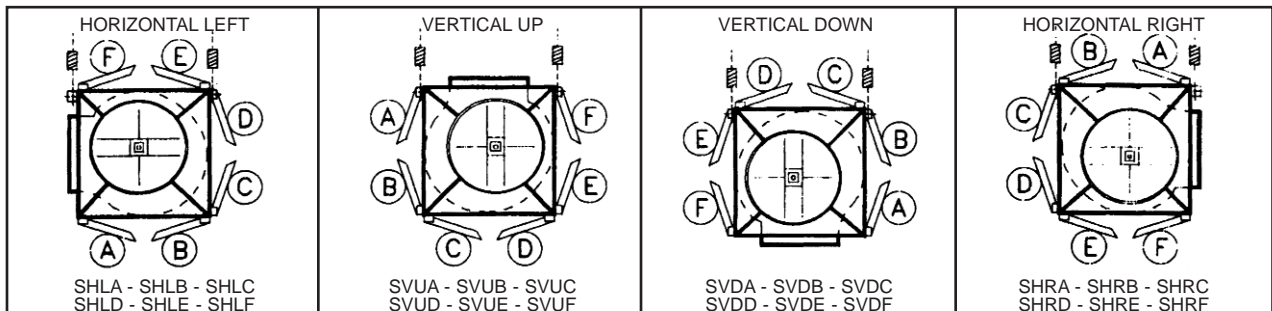

Horizontally Suspended

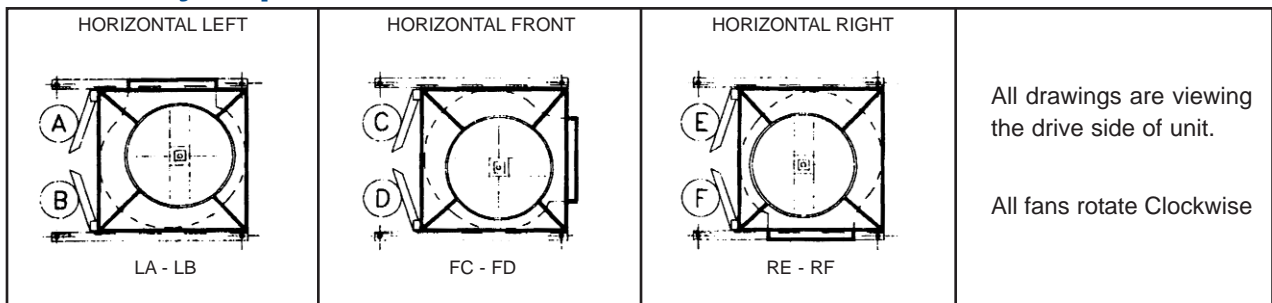

Ordering Instructions:

1. Specify discharge position and motor location. Motor location is always relative to discharge viewing the drive side of the fan.
2. Specify unit discharge and motor position by letter designation as shown above.

Example: If you want an "up" discharge with the motor on the lower left corner, you would specify an arrangement VUB

OV - Performance Data

Class I - Omnivent

122

Wheel Diameter = 12.250 in.	Tip Speed, FPM = 3.21 x RPM
Outlet Area = 0.860 sq. ft.	Maximum BHP = .09 x (RPM/1000) ³

Maximum RPM = 3118 (Class I)

CFM	OV	0.25" SP		0.50" SP		0.75" SP		1.00" SP		1.25" SP		1.50" SP		1.75" SP		2.00" SP		2.50" SP	
		RPM	BHP	RPM	BHP	RPM	BHP	RPM	BHP	RPM	BHP	RPM	BHP	RPM	BHP	RPM	BHP	RPM	BHP
800	930	903	0.06	1046	0.10	1208	0.14	1350	0.18	1486	0.23	1590	0.27	1705	0.33				
950	1104	1021	0.09	1144	0.13	1268	0.17	1403	0.22	1533	0.28	1645	0.33	1759	0.39	1852	0.44	2038	0.55
1100	1279	1145	0.13	1253	0.17	1357	0.22	1465	0.27	1682	0.33	1698	0.39	1803	0.45	1900	0.51	2092	0.64
1250	1453	1273	0.17	1368	0.22	1463	0.28	1553	0.33	1647	0.39	1753	0.45	1854	0.51	1955	0.58	2130	0.72
1400	1627	1404	0.22	1490	0.28	1574	0.34	1659	0.40	1738	0.46	1820	0.53	1914	0.59	2005	0.66	2186	0.82
1550	1802	1536	0.29	1615	0.35	1691	0.42	1768	0.49	1844	0.55	1915	0.62	1990	0.69	2069	0.76	2236	0.92
1700	1976	1670	0.37	1742	0.44	1813	0.51	1882	0.58	1952	0.65	2022	0.73	2085	0.80	2154	0.88	2299	1.04
1850	2151	1805	0.46	1872	0.53	1937	0.61	2001	0.69	2065	0.77	2129	0.85	2193	0.93	2252	1.01	2377	1.17
2000	2325	1941	0.56	2003	0.65	2064	0.73	2123	0.81	2182	0.90	2242	0.99	2301	1.07	2360	1.16	2471	1.33
2150	2500	2078	0.69	2135	0.77	2192	0.86	2249	0.95	2304	1.05	2358	1.14	2413	1.23	2469	1.32	2576	1.51
2300	2674	2215	0.83	2269	0.92	2322	1.02	2375	1.11	2427	1.21	2479	1.31	2529	1.41	2581	1.51	2684	1.70
2450	2848	2353	0.99	2403	1.09	2453	1.19	2503	1.29	2553	1.39	2601	1.50	2649	1.60	2697	1.71	2794	1.92
2600	3023	2491	1.17	2538	1.27	2586	1.38	2633	1.48	2680	1.59	2726	1.71	2771	1.82	2817	1.93	2908	2.15
2750	3197	2629	1.37	2674	1.48	2719	1.59	2764	1.70	2808	1.82	2852	1.93	2896	2.05	2939	2.17	3024	2.41
2900	3372	2768	1.59	2811	1.71	2853	1.82	2895	1.94	2938	2.06	2980	2.19	3022	2.31	3062	2.43		
3050	3546	2907	1.84	2947	1.96	2988	2.08	3028	2.21	3068	2.33	3108	2.46						
3200	3720	3046	2.11	3085	2.24														

CFM	OV	3.00" SP		3.50" SP		4.00" SP		4.50" SP		5.00" SP		5.50" SP		6.00" SP		6.50" SP		7.00" SP	
		RPM	BHP	RPM	BHP	RPM	BHP	RPM	BHP	RPM	BHP	RPM	BHP	RPM	BHP	RPM	BHP	RPM	BHP
1100	1279	2239	0.76																
1250	1453	2305	0.87	2445	1.01	2582	1.15												
1400	1627	2344	0.97	2500	1.13	2649	1.30	2761	1.44	2888	1.61	3021	1.80						
1550	1802	2400	1.09	2548	1.26	2685	1.43	2827	1.62	2956	1.80	3054	1.95						
1700	1976	2450	1.21	2600	1.39	2742	1.58	2865	1.76	2994	1.96								
1850	2151	2513	1.35	2652	1.53	2790	1.73	2925	1.94	3044	2.14								
2000	2325	2587	1.51	2715	1.70	2844	1.90	2971	2.11	3098	2.34								
2150	2500	2681	1.69	2788	1.89	2908	2.10	3029	2.31										
2300	2674	2782	1.90	2882	2.10	2982	2.31	3093	2.53										
2450	2848	2891	2.13	2981	2.33	3075	2.55												
2600	3023	2999	2.37	3090	2.60														
2750	3197	3110	2.64																

135

Wheel Diameter = 13.500 in.	Tip Speed, FPM = 3.53 x RPM
Outlet Area = 1.050 sq. ft.	Maximum BHP = .14 x (RPM/1000) ³

Maximum RPM = 2829 (Class I)

CFM	OV	0.25" SP		0.50" SP		0.75" SP		1.0" SP		1.25" SP		1.50" SP		1.75" SP		2.00" SP		2.50" SP	
		RPM	BHP	RPM	BHP	RPM	BHP	RPM	BHP	RPM	BHP	RPM	BHP	RPM	BHP	RPM	BHP	RPM	BHP
1000	957	888	0.10	1007	0.14	1121	0.20	1240	0.26	1361	0.33	1478	0.41	1587	0.49	1691	0.58		
1200	1148	1014	0.14	1124	0.20	1219	0.25	1314	0.32	1412	0.39	1512	0.47	1613	0.56	1712	0.65	1897	0.84
1400	1340	1142	0.20	1247	0.26	1335	0.33	1416	0.40	1497	0.47	1579	0.55	1664	0.64	1750	0.73	1923	0.93
1600	1531	1273	0.27	1373	0.35	1456	0.42	1531	0.50	1602	0.57	1673	0.66	1744	0.74	1817	0.84	1966	1.04
1800	1722	1406	0.36	1500	0.45	1581	0.54	1652	0.62	1718	0.70	1782	0.79	1845	0.88	1908	0.97	2035	1.18
2000	1914	1542	0.47	1628	0.57	1707	0.67	1777	0.76	1840	0.86	1899	0.95	1957	1.04	2014	1.14	2127	1.35
2200	2105	1680	0.60	1758	0.71	1834	0.82	1902	0.93	1964	1.03	2021	1.13	2075	1.23	2128	1.34	2231	1.55
2400	2297	1820	0.76	1890	0.88	1962	1.00	2029	1.12	2089	1.23	2145	1.35	2197	1.46	2248	1.57	2345	1.79
2600	2488	1962	0.95	2025	1.07	2092	1.20	2156	1.33	2215	1.46	2270	1.58	2322	1.71	2370	1.82	2463	2.07
2800	2679	2105	1.17	2161	1.29	2223	1.43	2285	1.58	2343	1.72	2396	1.85	2447	1.98	2495	2.11	2584	2.37
3000	2871	2248	1.41	2299	1.55	2356	1.70	2414	1.85	2470	2.00	2523	2.15	2573	2.29	2620	2.44	2708	2.71
3200	3062	2392	1.70	2438	1.84	2490	1.99	2545	2.15	2599	2.32	2651	2.48	2700	2.64	2746	2.79		
3400	3254	2536	2.02	2579	2.16	2627	2.32	2677	2.49	2729	2.67	2779	2.84	2827	3.01				
3600	3445	2680	2.38	2720	2.53	2764	2.70	2811	2.87										
3800	3636	2825	2.78																

CFM	OV	3.00" SP		3.50" SP		4.00" SP		4.50" SP		5.00" SP		5.50" SP		6.00" SP		6.50" SP		7.00" SP	
		RPM	BHP	RPM	BHP	RPM	BHP	RPM	BHP	RPM	BHP	RPM	BHP	RPM	BHP	RPM	BHP	RPM	BHP
1200	1148	2070	1.05																
1400	1340	2088	1.15	2243	1.39	2391	1.63	2535	1.88										
1600	1531	2118	1.26	2267	1.51	2409	1.76	2544	2.03	2675	2.31	2802	2.59						
1800	1722	2167	1.40	2302	1.65	2437	1.91	2568	2.19	2695	2.47	2816	2.77						
2000	1914	2241	1.57	2359	1.82	2480	2.08	2602	2.36	2722	2.66								
2200	2105	2334	1.78	2438	2.03	2545	2.29	2653	2.57	2763	2.86								
2400	2297	2439	2.03	2533	2.28	2628	2.54	2725	2.82	2823	3.11								
2600	2488	2551	2.31	2638	2.57	2725	2.84	2813	3.12										
2800	2679	2669	2.63	2751	2.90														
3000	2871	2790	2.99																

1. Bold figures indicate points of maximum static efficiency.
2. Performance ratings do not include effects of appurtenances in the airstream.
3. Performance shown is for installation type D: Ducted inlet, Ducted outlet.
4. Power rating (BHP) does not include drive losses.

Performance Data - OV

Omnivent - Class I

150

Wheel Diameter = 15.000 in.	Tip Speed, FPM = 3.93 x RPM
Outlet Area = 1.280 sq. ft.	Maximum BHP = .24 x (RPM/1000) ³

Maximum RPM = 2546 (Class I)

CFM	OV	0.25" SP		0.50" SP		0.75" SP		1.00" SP		1.25" SP		1.50" SP		1.75" SP		2.00" SP		2.50" SP	
		RPM	BHP	RPM	BHP	RPM	BHP	RPM	BHP	RPM	BHP	RPM	BHP	RPM	BHP	RPM	BHP	RPM	BHP
1300	1015	779	0.11	888	0.17	1006	0.23	1125	0.30	1226	0.37	1327	0.45						
1500	1171	867	0.15	964	0.22	1057	0.28	1161	0.36	1265	0.44	1357	0.52	1445	0.61	1533	0.70		
1700	1328	959	0.20	1044	0.27	1127	0.35	1209	0.42	1304	0.51	1395	0.60	1484	0.69	1560	0.78	1717	0.99
1900	1484	1052	0.26	1129	0.34	1205	0.42	1278	0.51	1352	0.59	1438	0.69	1519	0.78	1601	0.89	1744	1.09
2100	1640	1147	0.33	1217	0.42	1286	0.51	1355	0.60	1420	0.69	1487	0.79	1563	0.89	1638	1.00	1786	1.23
2300	1796	1243	0.42	1308	0.52	1371	0.62	1434	0.71	1496	0.81	1555	0.91	1617	1.02	1684	1.13	1821	1.36
2500	1953	1340	0.52	1400	0.62	1459	0.73	1516	0.84	1574	0.95	1631	1.05	1686	1.16	1743	1.27	1867	1.51
2700	2109	1438	0.64	1494	0.75	1548	0.86	1602	0.98	1656	1.09	1709	1.21	1761	1.32	1812	1.44	1916	1.68
2900	2265	1537	0.77	1589	0.89	1640	1.01	1690	1.14	1740	1.26	1790	1.39	1840	1.51	1888	1.63	1984	1.89
3100	2421	1636	0.93	1684	1.05	1733	1.18	1780	1.31	1827	1.45	1873	1.58	1920	1.71	1967	1.85	2055	2.11
3300	2578	1735	1.10	1781	1.23	1826	1.37	1871	1.51	1915	1.65	1959	1.79	2003	1.93	2047	2.07	2135	2.36
3500	2734	1835	1.29	1878	1.43	1921	1.58	1964	1.73	2005	1.88	2047	2.03	2088	2.18	2129	2.32	2212	2.63
3700	2890	1935	1.51	1976	1.66	2016	1.81	2057	1.97	2097	2.12	2136	2.28	2175	2.44	2214	2.60	2293	2.91
3900	3046	2035	1.75	2074	1.91	2113	2.07	2151	2.23	2189	2.39	2227	2.56	2264	2.73	2301	2.90	2375	3.23
4100	3203	2136	2.02	2172	2.18	2209	2.35	2246	2.52	2282	2.69	2319	2.86	2354	3.04	2390	3.22	2460	3.57
4300	3359	2236	2.31	2211	2.48	2306	2.66	2342	2.83	2376	3.01	2411	3.19	2446	3.38	2479	3.56		
4500	3515	2337	2.63	2371	2.81	2404	2.99	2438	3.18	2471	3.36	2504	3.55	2537	3.74				
4700	3671	2438	2.98	2470	3.17	2502	3.36	2534	3.55										
4900	3828	2539	3.36																

CFM	OV	3.00" SP		3.50" SP		4.00" SP		4.50" SP		5.00" SP		5.50" SP		6.00" SP		6.50" SP		7.00" SP	
		RPM	BHP	RPM	BHP	RPM	BHP	RPM	BHP	RPM	BHP	RPM	BHP	RPM	BHP	RPM	BHP	RPM	BHP
1900	1484	1885	1.32	2007	1.54														
2100	1640	1915	1.45	2042	1.70	2164	1.95												
2300	1796	1956	1.61	2075	1.86	2189	2.12	2306	2.40	2408	2.67								
2500	1953	1991	1.77	2115	2.04	2228	2.32	2331	2.59	2439	2.89	2543	3.20						
2700	2109	2037	1.95	2150	2.23	2266	2.53	2374	2.83	2469	3.11								
2900	2265	2083	2.15	2196	2.44	2301	2.73	2409	3.05	2513	3.38								
3100	2421	2147	2.39	2242	2.67	2348	2.99	2446	3.29										
3300	2578	2216	2.64	2303	2.94	2393	3.25	2493	3.58										
3500	2734	2292	2.92	2371	3.23	2453	3.54	2538	3.87										
3700	2890	2371	3.23	2444	3.54	2520	3.87												
3900	3046	2450	3.56	2524	3.90														
4100	3203	2531	3.92																

165

Wheel Diameter = 16.500 in.	Tip Speed, FPM = 4.32 x RPM
Outlet Area = 1.560 sq. ft.	Maximum BHP = .39 x (RPM/1000) ³

Maximum RPM = 2315 (Class I)

CFM	OV	0.25" SP		0.50" SP		0.75" SP		1.00" SP		1.25" SP		1.50" SP		1.75" SP		2.00" SP		2.50" SP	
		RPM	BHP	RPM	BHP	RPM	BHP	RPM	BHP	RPM	BHP	RPM	BHP	RPM	BHP	RPM	BHP	RPM	BHP
1500	961	685	0.12	789	0.19	903	0.26	1011	0.35	1108	0.43								
1750	1121	767	0.17	857	0.25	946	0.32	1045	0.41	1142	0.51	1224	0.60	1308	0.71				
2000	1282	852	0.23	931	0.31	1008	0.40	1088	0.49	1176	0.59	1261	0.70	1340	0.81	1411	0.92	1554	1.16
2250	1442	939	0.30	1010	0.40	1081	0.49	1149	0.59	1220	0.69	1298	0.81	1374	0.92	1449	1.05	1579	1.29
2500	1602	1028	0.39	1093	0.49	1156	0.60	1220	0.71	1280	0.82	1343	0.93	1415	1.06	1487	1.18	1618	1.46
2750	1762	1118	0.49	1178	0.61	1235	0.73	1293	0.84	1350	0.96	1405	1.08	1462	1.21	1525	1.34	1650	1.62
3000	1923	1209	0.62	1264	0.74	1318	0.87	1371	1.00	1424	1.13	1475	1.25	1526	1.38	1578	1.52	1693	1.81
3250	2083	1301	0.76	1352	0.89	1402	1.03	1451	1.17	1500	1.31	1549	1.45	1596	1.59	1642	1.73	1738	2.02
3500	2243	1394	0.93	1441	1.07	1488	1.22	1533	1.37	1579	1.52	1624	1.67	1670	1.82	1714	1.97	1801	2.27
3750	2403	1487	1.12	1531	1.27	1575	1.43	1618	1.59	1660	1.75	1702	1.91	1745	2.07	1788	2.23	1868	2.55
4000	2564	1580	1.34	1621	1.50	1663	1.66	1704	1.83	1743	2.00	1783	2.18	1823	2.35	1863	2.52	1943	2.86
4250	2724	1674	1.58	1713	1.75	1752	1.93	1790	2.11	1828	2.29	1866	2.47	1903	2.65	1940	2.83	2016	3.20
4500	2884	1768	1.85	1805	2.03	1841	2.22	1878	2.41	1914	2.60	1950	2.79	1985	2.98	2020	3.18	2091	3.56
4750	3044	1862	2.16	1897	2.35	1932	2.54	1966	2.74	2001	2.94	2035	3.14	2069	3.35	2102	3.55	2169	3.95
5000	3205	1956	2.50	1989	2.70	2023	2.90	2056	3.11	2089	3.31	2121	3.53	2153	3.74	2185	3.96	2249	4.39
5200	3365	2049	2.87	2082	3.08	2114	3.29	2146	3.51	2177	3.72	2208	3.95	2239	4.17	2270	4.39		
5500	3525	2145	3.28	2176	3.50	2206	3.72	2236	3.94	2266	4.17	2296	4.40						
5750	3685	2240	3.73	2269	3.95	2298	4.18												

CFM	OV	3.00" SP		3.50" SP		4.00" SP		4.50" SP		5.00" SP		5.50" SP		6.00" SP		6.50" SP		7.00" SP	
		RPM	BHP	RPM	BHP	RPM	BHP	RPM	BHP	RPM	BHP	RPM	BHP	RPM	BHP	RPM	BHP	RPM	BHP
2250	1442	1709	1.57																
2500	1602	1734	1.72	1853	2.02														
2750	1762	1774	1.93	1881	2.22	1987	2.53	2093	2.88										
3000	1923	1806	2.12	1920	2.45	2021	2.77	2116	3.10	2215	3.47	2309	3.84						
3250	2083	1849	2.35	1952	2.68	2058	3.04	2156	3.40	2242	3.74								
3500	2243	1892	2.59	1995	2.95	2091	3.30	2189	3.69	2284	4.08								
3750	2403	1952	2.89	2038	3.23	2134	3.61	2223	3.98										
4000	2564	2017	3.20	2095	3.56	2177	3.94	2268	4.34										
4250	2724	2088	3.56	2160	3.93	2233	4.31	2310	4.71										
4500	2884	2162	3.95	2229	4.33	2297	4.72												
4750	3044	2236	4.36	2304	4.77														
5000	3205	2313	4.91																

1. Bold figures indicate points of maximum static efficiency.
2. Performance ratings do not include effects of appurtenances in the airstream.
3. Performance shown is for installation type D: Ducted inlet, Ducted outlet.
4. Power rating (BHP) does not include drive losses.

OV - Performance Data

Omnivent - Class I

182

Wheel Diameter = 18.250 in.	Tip Speed, FPM = 4.78 x RPM
Outlet Area = 1.900 sq. ft.	Maximum BHP = .65 x (RPM/1000) ³

Maximum RPM = 2093 (Class I)

CFM	OV	SP = 0.25		SP = 0.50		SP = 0.75		SP = 1.00		SP = 1.25		SP = 1.50		SP = 1.75		SP = 2.00		SP = 2.50	
		RPM	BHP	RPM	BHP	RPM	BHP	RPM	BHP	RPM	BHP	RPM	BHP	RPM	BHP	RPM	BHP	RPM	BHP
1900	1000	635	0.16	725	0.25	824	0.34	922	0.44	1006	0.55	1113	0.76	1187	0.89				
2200	1157	708	0.22	788	0.32	865	0.41	952	0.52	1038	0.64	1145	0.88	1218	1.02	1281	1.15	1410	1.45
2500	1315	784	0.29	854	0.40	923	0.51	992	0.62	1070	0.74	1145	0.88	1218	1.02	1281	1.15	1410	1.45
2800	1473	861	0.38	925	0.50	988	0.62	1048	0.74	1109	0.87	1180	1.01	1247	1.15	1315	1.31	1432	1.61
3100	1631	940	0.49	998	0.62	1055	0.75	1112	0.89	1165	1.02	1221	1.16	1284	1.32	1345	1.47	1467	1.81
3400	1789	1020	0.62	1074	0.76	1125	0.91	1177	1.05	1228	1.20	1277	1.35	1328	1.50	1383	1.66	1496	2.00
3700	1947	1101	0.77	1151	0.92	1199	1.08	1246	1.24	1294	1.40	1340	1.56	1385	1.72	1432	1.88	1534	2.24
4000	2105	1183	0.95	1229	1.11	1273	1.28	1317	1.45	1361	1.62	1406	1.80	1448	1.96	1490	2.14	1575	2.50
4300	2263	1265	1.15	1308	1.32	1350	1.51	1391	1.69	1432	1.87	1473	2.06	1514	2.24	1554	2.42	1632	2.80
4600	2421	1347	1.38	1387	1.57	1427	1.76	1466	1.95	1504	2.15	1542	2.35	1581	2.54	1619	2.74	1692	3.13
4900	2578	1430	1.64	1468	1.84	1505	2.04	1542	2.25	1578	2.46	1614	2.67	1650	2.88	1686	3.09	1758	3.51
5200	2736	1513	1.93	1549	2.14	1584	2.36	1619	2.58	1653	2.80	1687	3.02	1721	3.25	1755	3.47	1823	3.91
5500	2894	1597	2.26	1630	2.48	1663	2.71	1697	2.94	1729	3.17	1762	3.41	1794	3.64	1825	3.88	1890	4.35
5800	3052	1680	2.63	1712	2.86	1744	3.10	1775	3.34	1806	3.58	1837	3.83	1868	4.08	1898	4.33	1958	4.82
6100	3210	1764	3.03	1794	3.27	1824	3.52	1854	3.77	1884	4.03	1914	4.29	1943	4.55	1972	4.81	2029	5.34
5400	3368	1848	3.48	1876	3.73	1905	3.99	1934	4.25	1962	4.52	1991	4.79	2019	5.06	2046	5.33		
5700	3526	1932	3.96	1959	4.23	1987	4.50	2014	4.77	2041	5.05	2068	5.33						
7000	3684	2016	4.49	2042	4.77	2068	5.05												

CFM	OV	SP = 3.00		SP = 3.50		SP = 4.00		SP = 4.50		SP = 5.00		SP = 5.50		SP = 6.00		SP = 6.50		SP = 7.00	
		RPM	BHP	RPM	BHP	RPM	BHP	RPM	BHP	RPM	BHP	RPM	BHP	RPM	BHP	RPM	BHP	RPM	BHP
2800	1473	1549	1.95																
3100	1631	1573	2.14	1678	2.51														
3400	1789	1607	2.38	1705	2.75	1799	3.13	1895	3.55										
3700	1947	1636	2.61	1739	3.03	1831	3.43	1916	3.83	2005	4.27	2090	4.73						
4000	2105	1675	2.90	1768	3.30	1863	3.74	1952	4.19	2030	4.60								
4300	2263	1713	3.19	1806	3.63	1892	4.06	1981	4.53	2067	5.01								
4600	2421	1767	3.55	1844	3.97	1931	4.43	2012	4.89										
4900	2578	1825	3.93	1896	4.37	1969	4.83	2051	5.32										
5200	2736	1888	4.35	1953	4.81	2019	5.28	2089	5.75										
5500	2894	1954	4.82	2014	5.28	2076	5.77												
5800	3052	2020	5.32	2080	5.82														
6100	3210	2087	5.85																

200

Wheel Diameter = 20.000 in.	Tip Speed, FPM = 5.24 x RPM
Outlet Area = 2.300 sq. ft.	Maximum BHP = .98 x (RPM/1000) ³

Maximum RPM = 1910 (Class I)

CFM	OV	0.25" SP		0.50" SP		0.75" SP		1.00" SP		1.25" SP		1.50" SP		1.75" SP		2.00" SP		2.50" SP	
		RPM	BHP	RPM	BHP	RPM	BHP	RPM	BHP	RPM	BHP	RPM	BHP	RPM	BHP	RPM	BHP	RPM	BHP
2300	1000	574	0.18	658	0.28	743	0.38	825	0.49	896	0.60								
2650	1152	636	0.24	710	0.34	782	0.46	857	0.58	929	0.71	996	0.84	1054	0.97				
3000	1304	702	0.31	768	0.43	832	0.56	895	0.69	962	0.83	1027	0.97	1088	1.11	1144	1.26		
3350	1456	768	0.40	829	0.53	887	0.66	944	0.81	1000	0.97	1060	1.12	1121	1.27	1175	1.43	1279	1.76
3700	1608	837	0.51	891	0.65	945	0.80	997	0.95	1049	1.12	1100	1.29	1154	1.45	1208	1.63	1310	1.97
4050	1760	906	0.64	956	0.79	1005	0.95	1054	1.11	1101	1.28	1149	1.46	1195	1.65	1244	1.83	1343	2.21
4400	1913	976	0.79	1022	0.96	1068	1.12	1113	1.30	1158	1.47	1200	1.66	1244	1.86	1288	2.06	1377	2.46
4750	2065	1046	0.97	1089	1.14	1132	1.32	1174	1.51	1216	1.70	1256	1.89	1296	2.10	1337	2.31	1416	2.74
5100	2217	1117	1.17	1157	1.36	1197	1.55	1236	1.74	1276	1.94	1315	2.15	1352	2.36	1389	2.58	1465	3.04
5450	2369	1188	1.40	1226	1.60	1263	1.80	1300	2.01	1337	2.22	1374	2.44	1410	2.66	1445	2.88	1515	3.36
5800	2521	1260	1.66	1295	1.87	1330	2.09	1366	2.31	1400	2.52	1435	2.75	1469	2.98	1503	3.22	1568	3.70
6150	2673	1332	1.95	1365	2.17	1398	2.40	1432	2.64	1464	2.87	1497	3.10	1530	3.34	1562	3.59	1625	4.08
6500	2826	1404	2.28	1435	2.51	1467	2.75	1498	3.00	1530	3.24	1560	3.48	1591	3.73	1622	3.99	1683	4.52
6850	2978	1477	2.64	1506	2.88	1536	3.14	1566	3.39	1596	3.65	1625	3.91	1654	4.16	1683	4.43	1742	4.98
7200	3130	1549	3.04	1577	3.30	1605	3.56	1634	3.83	1662	4.10	1691	4.37	1718	4.64	1746	4.91	1802	5.48
7550	3282	1622	3.48	1649	3.75	1675	4.02	1702	4.30	1730	4.58	1757	4.87	1784	5.16	1810	5.43	1863	6.02
7900	3434	1694	3.96	1720	4.24	1746	4.52	1772	4.81	1797	5.11	1823	5.41	1849	5.71	1875	6.00		
8250	3586	1767	4.48	1792	4.77	1816	5.07	1841	5.37	1866	5.68	1891	5.99						
8600	3739	1840	5.05	1864	5.35	1887	5.66												

CFM	OV	3.00" SP		3.50" SP		4.00" SP		4.50" SP		5.00" SP		5.50" SP		6.00" SP		6.50" SP		7.00" SP	
		RPM	BHP	RPM	BHP	RPM	BHP	RPM	BHP	RPM	BHP	RPM	BHP	RPM	BHP	RPM	BHP	RPM	BHP
3700	1608	1404	2.34																
4050	1760	1434	2.59	1522	2.99	1597	3.38												
4400	1913	1468	2.87	1551	3.28	1633	3.72	1704	4.14										
4750	2065	1501	3.17	1586	3.62	1663	4.05	1739	4.53	1810	5.00	1872	5.45						
5100	2217	1539	3.50	1618	3.97	1697	4.45	1769	4.91	1841	5.41								
5450	2369	1586	3.85	1656	4.34	1730	4.85	1803	5.36	1872	5.85								
5800	2521	1635	4.22	1701	4.75	1767	5.27	1836	5.81	1906	6.36								
6150	2673	1686	4.62	1750	5.18	1811	5.74	1874	6.29										
6500	2826	1741	5.06	1800	5.63	1860	6.22												
6850	2978	1799	5.53	1853	6.12	1910	6.73												
7200	3130	1857	6.06	1910	6.64														

1. Bold figures indicate points of maximum static efficiency.
2. Performance ratings do not include effects of appurtenances in the airstream.
3. Performance shown is for installation type D: Ducted inlet, Ducted outlet.
4. Power rating (BHP) does not include drive losses.

Performance Data - OV

Omnivent - Class I

222

Wheel Diameter = 22.250 in.	Tip Speed, FPM = 5.83 x RPM
Outlet Area = 2.830 sq. ft.	Maximum BHP = 1.67 x (RPM/1000) ³

Maximum RPM = 1717 (Class I)

CFM	OV	0.25" SP		0.50" SP		0.75" SP		1.00" SP		1.25" SP		1.50" SP		1.75" SP		2.00" SP		2.50" SP	
		RPM	BHP	RPM	BHP	RPM	BHP	RPM	BHP	RPM	BHP	RPM	BHP	RPM	BHP	RPM	BHP	RPM	BHP
2800	989	510	0.21	587	0.33	665	0.46	739	0.59										
3250	1148	568	0.29	635	0.42	700	0.57	769	0.71	833	0.80	894	1.03						
3700	1307	629	0.38	689	0.53	746	0.68	804	0.85	864	1.02	922	1.19	977	1.37	1028	1.56		
4150	1466	691	0.50	745	0.66	798	0.82	849	1.01	900	1.20	953	1.39	1008	1.58	1056	1.77	1150	2.18
4600	1625	755	0.64	804	0.81	852	0.99	898	1.19	945	1.39	991	1.60	1039	1.81	1087	2.02	1178	2.45
5050	1784	819	0.81	864	1.00	909	1.19	952	1.39	994	1.61	1036	1.83	1078	2.07	1121	2.29	1210	2.76
5500	1943	885	1.01	926	1.21	967	1.42	1007	1.64	1047	1.86	1085	2.09	1124	2.34	1163	2.59	1242	3.09
5950	2102	951	1.24	989	1.46	1027	1.68	1064	1.91	1102	2.15	1138	2.39	1173	2.64	1209	2.91	1280	3.46
6400	2261	1017	1.50	1053	1.74	1088	1.98	1123	2.22	1158	2.47	1193	2.73	1226	2.99	1258	3.26	1326	3.84
6850	2420	1084	1.81	1117	2.06	1150	2.31	1183	2.57	1215	2.83	1248	3.10	1280	3.38	1312	3.66	1373	4.25
7300	2579	1151	2.15	1182	2.42	1213	2.69	1244	2.97	1275	3.24	1305	3.52	1336	3.81	1366	4.11	1424	4.71
7750	2738	1218	2.54	1247	2.82	1277	3.11	1306	3.40	1335	3.69	1364	3.98	1392	4.28	1421	4.60	1478	5.22
8200	2897	1286	2.98	1313	3.27	1341	3.57	1368	3.88	1396	4.19	1423	4.49	1450	4.81	1478	5.13	1532	5.79
8650	3056	1353	3.46	1379	3.77	1405	4.08	1432	4.40	1458	4.73	1484	5.06	1510	5.38	1535	5.71	1587	6.40
9100	3215	1421	3.99	1446	4.32	1471	4.65	1495	4.98	1520	5.33	1545	5.67	1570	6.01	1594	6.35	1644	7.06
9550	3374	1489	4.58	1512	4.92	1536	5.26	1560	5.62	1584	5.97	1607	6.33	1631	6.70	1654	7.05	1701	7.78
10000	3533	1557	5.22	1579	5.58	1602	5.94	1625	6.30	1647	6.68	1670	7.05	1693	7.43	1715	7.82		
10450	3692	1625	5.93	1646	6.30	1668	6.67	1690	7.05	1711	7.44								
10900	3851	1693	6.69	1714	7.08														

CFM	OV	3.00" SP		3.50" SP		4.00" SP		4.50" SP		5.00" SP		5.50" SP		6.00" SP		6.50" SP		7.00" SP	
		RPM	BHP	RPM	BHP	RPM	BHP	RPM	BHP	RPM	BHP	RPM	BHP	RPM	BHP	RPM	BHP	RPM	BHP
4600	1625	1264	2.91																
5050	1784	1292	3.23	1371	3.74														
5500	1943	1323	3.60	1395	4.11	1472	4.66	1537	5.19										
5950	2102	1355	3.99	1430	4.55	1499	5.09	1568	5.68	1632	6.28	1688	6.83						
6400	2261	1391	4.42	1461	5.00	1531	5.61	1597	6.18	1660	6.80								
6850	2420	1436	4.88	1497	5.50	1563	6.12	1628	6.77	1691	7.39								
7300	2579	1482	5.36	1541	6.03	1599	6.68	1660	7.35										
7750	2738	1531	5.89	1557	6.58	1642	7.29	1696	7.99										
8200	2897	1583	6.46	1635	7.18	1688	7.92												
8650	3056	1638	7.10	1686	7.83														
9100	3215	1693	7.80																

245

Wheel Diameter = 24.500 in.	Tip Speed, FPM = 6.41 x RPM
Outlet Area = 3.450 sq. ft.	Maximum BHP = 2.71 x (RPM/1000) ³

Maximum RPM = 1559 (Class I)

CFM	OV	0.25" SP		0.50" SP		0.75" SP		1.00" SP		1.25" SP		1.50" SP		1.75" SP		2.00" SP		2.50" SP	
		RPM	BHP	RPM	BHP	RPM	BHP	RPM	BHP	RPM	BHP	RPM	BHP	RPM	BHP	RPM	BHP	RPM	BHP
3400	985	464	0.26	533	0.40	604	0.56	671	0.72										
3900	1130	512	0.34	573	0.50	633	0.68	696	0.86	755	1.04	809	1.23						
4400	1275	562	0.44	618	0.62	671	0.81	724	1.00	780	1.21	833	1.41	883	1.63	927	1.84		
4900	1420	614	0.57	664	0.76	713	0.96	761	1.17	809	1.40	859	1.62	908	1.85	953	2.08	1036	2.56
5400	1565	667	0.72	712	0.92	758	1.14	801	1.36	845	1.61	888	1.85	933	2.10	979	2.35	1062	2.86
5900	1710	720	0.89	762	1.11	804	1.34	845	1.58	884	1.84	924	2.10	963	2.37	1005	2.64	1087	3.19
6400	1855	774	1.10	813	1.34	852	1.58	890	1.84	927	2.10	963	2.38	1000	2.67	1036	2.96	1113	3.55
6900	2000	829	1.33	865	1.59	901	1.85	937	2.12	972	2.40	1005	2.68	1039	2.99	1074	3.30	1142	3.92
7400	2144	884	1.61	918	1.88	951	2.16	984	2.44	1018	2.73	1050	3.03	1081	3.34	1113	3.67	1177	4.34
7900	2289	939	1.91	971	2.20	1003	2.50	1034	2.80	1065	3.10	1096	3.42	1126	3.74	1155	4.07	1215	4.78
8400	2434	995	2.26	1024	2.57	1054	2.88	1084	3.20	1113	3.51	1142	3.85	1171	4.19	1200	4.52	1255	5.25
8900	2579	1051	2.65	1079	2.97	1107	3.30	1135	3.64	1162	3.97	1190	4.32	1218	4.67	1245	5.03	1297	5.77
9400	2724	1107	3.08	1133	3.42	1160	3.77	1186	4.13	1213	4.48	1239	4.83	1265	5.20	1291	5.58	1342	6.33
9900	2869	1163	3.56	1188	3.92	1213	4.28	1238	4.65	1264	5.03	1288	5.40	1313	5.78	1338	6.17	1387	6.97
10400	3014	1219	4.09	1243	4.47	1267	4.85	1291	5.23	1315	5.63	1339	6.02	1362	6.41	1386	6.81	1433	7.64
10900	3159	1275	4.68	1298	5.06	1321	5.46	1344	5.86	1367	6.28	1390	6.69	1412	7.10	1435	7.50	1480	8.36
11400	3304	1332	5.31	1354	5.72	1375	6.13	1397	6.55	1419	6.98	1441	7.41	1463	7.85	1484	8.26	1528	9.14
11900	3449	1388	6.00	1409	6.43	1430	6.85	1451	7.29	1472	7.73	1493	8.18	1514	8.64	1535	9.08		
12400	3594	1445	6.76	1465	7.19	1485	7.64	1505	8.09	1525	8.55	1545	9.02						
12900	3739	1502	7.57	1521	8.02	1540	8.49												
13400	3884	1558	8.45																

CFM	OV	3.00" SP		3.50" SP		4.00" SP		4.50" SP		5.00" SP		5.50" SP		6.00" SP		6.50" SP		7.00" SP	
		RPM	BHP	RPM	BHP	RPM	BHP	RPM	BHP	RPM	BHP	RPM	BHP	RPM	BHP	RPM	BHP	RPM	BHP
5400	1565	1137	3.39																
5900	1710	1163	3.75	1232	4.33														
6400	1855	1187	4.13	1257	4.75	1323	5.39												
6900	2000	1213	4.57	1282	5.20	1347	5.86	1409	6.56	1463	7.20								
7400	2144	1241	5.01	1307	5.70	1372	6.37	1432	7.08	1492	7.83	1545	8.54						
7900	2289	1273	5.50	1335	6.21	1397	6.96	1458	7.67	1514	8.41								
8400	2434	1311	6.01	1366	6.78	1424	7.53	1483	8.33	1541	9.09								
8900	2579	1350	6.55	1403	7.37	1455	8.17	1510	8.98										
9400	2724	1391	7.14	1441	7.98	1491	8.85	1541	9.69										
9900	2869	1434	7.78	1481	8.65	1529	9.54												
10400	3014	1480	8.47	1523	9.36														
10900	3159	1525	9.24																

1. Bold figures indicate points of maximum static efficiency.
2. Performance ratings do not include effects of appurtenances in the airstream.
3. Performance shown is for installation type D: Ducted inlet, Ducted outlet.
4. Power rating (BHP) does not include drive losses.

OV - Performance Data

Omnivent - Class I

270

Wheel Diameter = 27.000 in.	Tip Speed, FPM = 7.07 x RPM
Outlet Area = 4.200 sq. ft.	Maximum BHP = 41.2 x (RPM/1000) ³

Maximum RPM = 1415 (Class I)

CFM	OV	0.25" SP		0.50" SP		0.75" SP		1.00" SP		1.25" SP		1.50" SP		1.75" SP		2.00" SP		2.50" SP	
		RPM	BHP	RPM	BHP	RPM	BHP	RPM	BHP	RPM	BHP	RPM	BHP	RPM	BHP	RPM	BHP	RPM	BHP
4200	1000	426	0.31	488	0.47	547	0.65	600	0.84										
4800	1142	468	0.41	525	0.59	577	0.78	630	0.98	683	1.20	733	1.44						
5400	1285	512	0.53	565	0.73	613	0.94	659	1.15	706	1.38	752	1.62	799	1.89				
6000	1428	558	0.68	606	0.89	651	1.12	693	1.36	735	1.60	777	1.85	819	2.11	861	2.40		
6600	1571	605	0.85	648	1.09	691	1.33	730	1.59	769	1.85	806	2.11	845	2.39	883	2.67	959	3.30
7200	1714	653	1.06	692	1.31	732	1.57	770	1.85	805	2.13	840	2.42	875	2.70	910	3.01	980	3.63
7800	1857	702	1.31	736	1.57	774	1.85	810	2.14	844	2.45	876	2.75	909	3.06	941	3.37	1006	4.02
8400	2000	752	1.59	783	1.87	817	2.17	851	2.47	884	2.80	915	3.13	945	3.45	975	3.78	1035	4.46
9000	2142	801	1.92	829	2.21	861	2.52	893	2.85	925	3.18	955	3.53	984	3.89	1011	4.23	1068	4.94
9600	2285	851	2.29	877	2.59	906	2.92	936	3.26	966	3.61	995	3.98	1023	4.35	1050	4.73	1103	5.47
10200	2428	902	2.71	925	3.02	952	3.36	980	3.73	1008	4.09	1037	4.47	1063	4.86	1090	5.26	1139	6.05
10800	2571	952	3.17	974	3.50	998	3.86	1024	4.23	1051	4.62	1078	5.01	1105	5.41	1130	5.83	1179	6.68
11400	2714	1003	3.69	1023	4.04	1045	4.40	1070	4.80	1095	5.21	1121	5.61	1146	6.03	1171	6.46	1218	7.34
12000	2857	1054	4.27	1073	4.63	1093	5.01	1116	5.42	1139	5.84	1164	6.27	1188	6.70	1212	7.14	1258	8.06
12600	3000	1105	4.91	1123	5.28	1142	5.67	1163	6.09	1185	6.53	1208	6.98	1231	7.43	1254	7.89	1299	8.83
13200	3142	1156	5.60	1173	5.99	1191	6.40	1210	6.83	1231	7.28	1252	7.74	1275	8.22	1297	8.69	1340	9.66
13800	3285	1207	6.37	1223	6.77	1240	7.19	1258	7.63	1278	8.10	1298	8.58	1319	9.07	1340	9.56	1382	10.57
14400	3428	1258	7.20	1273	7.62	1289	8.05	1306	8.51	1324	8.98	1344	9.48	1363	9.98	1384	10.50		
15000	3571	1309	8.10	1324	8.53	1339	8.98	1355	9.45	1372	9.94	1390	10.45	1409	10.97				
15600	3714	1360	9.07	1374	9.52	1389	9.99	1404	10.47										
16200	3857	1412	10.13																

CFM	OV	3.00" SP		3.50" SP		4.00" SP		4.50" SP		5.00" SP		5.50" SP		6.00" SP		6.50" SP		7.00" SP	
		RPM	BHP	RPM	BHP	RPM	BHP	RPM	BHP	RPM	BHP	RPM	BHP	RPM	BHP	RPM	BHP	RPM	BHP
7200	1714	1050	4.32																
7800	1857	1070	4.74	1135	5.46	1196	6.21												
8400	2000	1095	5.16	1155	5.91	1215	6.72	1273	7.54										
9000	2142	1124	5.68	1179	6.44	1235	7.24	1292	8.11	1347	8.99								
9600	2285	1155	6.23	1208	7.03	1260	7.84	1312	8.69	1365	9.61								
10200	2428	1189	6.86	1238	7.66	1288	8.52	1337	9.38	1386	10.28								
10800	2571	1225	7.51	1272	8.37	1318	9.23	1365	10.15	1411	11.05								
11400	2714	1263	8.23	1307	9.12	1352	10.03	1395	10.94										
12000	2857	1302	9.00	1344	9.92	1386	10.87												
12600	3000	1342	9.81	1383	10.80														
13200	3142	1382	10.67																

300

Wheel Diameter = 30.000 in.	Tip Speed, FPM = 7.85 x RPM
Outlet Area = 5.150 sq. ft.	Maximum BHP = 6.86 x (RPM/1000) ³

Maximum RPM = 1273 (Class I)

CFM	OV	0.25" SP		0.50" SP		0.75" SP		1.00" SP		1.25" SP		1.50" SP		1.75" SP		2.00" SP		2.50" SP	
		RPM	BHP	RPM	BHP	RPM	BHP	RPM	BHP	RPM	BHP	RPM	BHP	RPM	BHP	RPM	BHP	RPM	BHP
5100	990	379	0.37	435	0.57	490	0.78	545	1.02										
5900	1145	420	0.50	471	0.72	519	0.96	566	1.20	614	1.48								
6700	1300	463	0.66	510	0.91	553	1.17	594	1.43	636	1.72	678	2.02	720	2.34				
7500	1456	507	0.86	550	1.13	590	1.42	628	1.71	665	2.01	703	2.33	740	2.65	777	3.00		
8300	1611	553	1.10	592	1.39	629	1.70	664	2.03	698	2.35	732	2.68	766	3.03	799	3.38	867	4.15
9100	1766	600	1.39	634	1.71	669	2.04	703	2.39	734	2.74	765	3.10	796	3.46	827	3.83	888	4.61
9900	1922	648	1.74	678	2.07	711	2.42	742	2.79	773	3.18	801	3.56	830	3.95	858	4.34	914	5.16
10700	2077	696	2.14	723	2.49	753	2.87	783	3.25	812	3.66	839	4.08	866	4.49	892	4.91	944	5.76
11500	2233	745	2.60	769	2.97	796	3.36	824	3.78	852	4.20	878	4.64	904	5.09	928	5.54	977	6.44
12300	2388	794	3.13	815	3.51	840	3.93	866	4.37	892	4.81	918	5.27	942	5.74	967	6.23	1012	7.18
13100	2543	843	3.73	863	4.13	885	4.57	909	5.02	934	5.49	958	5.97	982	6.46	1005	6.97	1049	8.00
13900	2699	892	4.40	911	4.82	931	5.27	953	5.75	976	6.25	1000	6.75	1023	7.26	1045	7.78	1088	8.87
14700	2854	941	5.16	959	5.60	977	6.06	998	6.56	1019	7.08	1042	7.60	1063	8.14	1085	8.68	1126	9.80
15500	3009	991	6.00	1007	6.46	1024	6.94	1043	7.45	1063	7.99	1084	8.55	1105	9.10	1126	9.66	1166	10.82
16300	3165	1040	6.92	1056	7.40	1072	7.91	1089	8.43	1108	8.99	1127	9.57	1147	10.15	1167	10.73	1206	11.93
17100	3320	1090	7.94	1104	8.44	1120	8.97	1136	9.51	1153	10.09	1171	10.68	1190	11.29	1209	11.90	1247	13.14
17900	3475	1140	9.06	1153	9.58	1168	10.12	1183	10.69	1199	11.27	1216	11.89	1234	12.52	1252	13.16		
18700	3631	1189	10.29	1203	10.83	1216	11.39	1231	11.97	1245	12.57	1262	13.21						
19500	3786	1239	11.61	1252	12.18	1265	12.76												

CFM	OV	3.00" SP		3.50" SP		4.00" SP		4.50" SP		5.00" SP		5.50" SP		6.00" SP		6.50" SP		7.00" SP	
		RPM	BHP	RPM	BHP	RPM	BHP	RPM	BHP	RPM	BHP	RPM	BHP	RPM	BHP	RPM	BHP	RPM	BHP
9100	1766	950	5.46																
9900	1922	971	6.00	1028	6.94	1083	7.91												
10700	2077	997	6.66	1049	7.57	1101	8.57	1153	9.82										
11500	2233	1026	7.36	1075	8.34	1123	9.31	1172	10.38	1220	11.50								
12300	2388	1058	8.16	1103	9.14	1149	10.20	1194	11.23	1240	12.35								
13100	2543	1092	9.01	1135	10.05	1177	11.11	1221	12.23	1263	13.32								
13900	2699	1128	9.95	1169	11.04	1209	12.14	1249	13.27										
14700	2854	1166	10.96	1204	12.09	1243	13.26												
15500	3009	1205	12.03	1242	13.25														
16300	3165	1244	13.18																

1. Bold figures indicate points of maximum static efficiency.
2. Performance ratings do not include effects of appurtenances in the airstream.
3. Performance shown is for installation type D: Ducted inlet, Ducted outlet.
4. Power rating (BHP) does not include drive losses.

Performance Data - OV

Omnivent - Class I & II

330

Wheel Diameter = 33.000 in.	Tip Speed, FPM = 8.64 x RPM
Outlet Area = 6.270 sq. ft.	Maximum BHP = 11.2 x (RPM/1000) ³

Maximum RPM = 1157 (Class I)
Maximum RPM = 1563 (Class II)

CFM	OV	0.25" SP		0.50" SP		0.75" SP		1.00" SP		1.25" SP		1.50" SP		1.75" SP		2.00" SP		2.50" SP	
		RPM	BHP	RPM	BHP	RPM	BHP	RPM	BHP	RPM	BHP	RPM	BHP	RPM	BHP	RPM	BHP	RPM	BHP
6200	988	345	0.45	397	0.69	446	0.95	496	1.24										
7200	1148	384	0.61	431	0.89	473	1.17	516	1.47										
8200	1307	424	0.82	467	1.12	506	1.44	543	1.77	559	1.80								
9200	1467	467	1.08	505	1.41	541	1.76	575	2.12	608	2.48	642	2.47	656	2.87				
10200	1626	510	1.39	544	1.74	578	2.12	610	2.52	640	2.92	670	3.32	700	3.74	730	4.17	791	5.11
11200	1786	554	1.76	584	2.15	616	2.55	646	2.98	674	3.42	702	3.85	729	4.30	757	4.75	812	5.69
12200	1945	599	2.21	626	2.61	655	3.05	683	3.50	710	3.97	736	4.45	761	4.92	787	5.41	837	6.40
13200	2105	645	2.73	668	3.15	694	3.62	721	4.09	747	4.59	772	5.10	796	5.62	819	6.13	866	7.17
14200	2264	690	3.33	711	3.77	735	4.26	760	4.77	785	5.29	809	5.83	832	6.39	854	6.95	898	8.05
15200	2424	736	4.01	755	4.48	777	5.00	800	5.54	824	6.08	847	6.64	869	7.22	890	7.82	931	9.00
16200	2583	782	4.80	800	5.29	820	5.82	841	6.39	863	6.96	885	7.55	906	8.15	927	8.78	967	10.05
17200	2743	829	5.68	845	6.19	863	6.74	882	7.34	903	7.95	924	8.56	944	9.19	964	9.83	1003	11.16
18200	2902	875	6.66	890	7.20	907	7.78	925	8.39	944	9.02	963	9.68	983	10.33	1002	11.00	1039	12.38
19200	3062	921	7.76	936	8.32	951	8.92	968	9.55	985	10.21	1003	10.89	1022	11.58	1041	12.27	1077	13.70
20200	3221	968	8.97	982	9.56	996	10.18	1011	10.83	1028	11.52	1044	12.22	1062	12.95	1080	13.67	1115	15.15
21200	3381	1015	10.31	1027	10.93	1041	11.57	1055	12.24	1070	12.95	1086	13.68	1103	14.42	1120	15.19	1153	16.72
22200	3540	1061	11.78	1074	12.42	1086	13.09	1100	13.78	1114	14.50	1129	15.26	1144	16.03	1160	16.82	1192	18.41
23200	3700	1108	13.38	1120	14.05	1132	14.74	1144	15.46	1157	16.20	1171	16.98	1186	17.78	1201	18.59	1232	20.25
24200	3859	1155	15.13	1166	15.82	1177	16.54	1189	17.28	1202	18.04	1215	18.83	1229	19.66	1243	20.50	1272	22.23
25200	4019	1202	17.02	1212	17.74	1223	18.48	1235	19.25	1246	20.04	1258	20.85	1271	21.69	1285	22.56	1312	24.33
26200	4178	1249	19.07	1259	19.82	1269	20.58	1280	21.37	1291	22.18	1303	23.02	1315	23.87	1327	24.77	1353	26.59
27200	4338	1296	21.28	1305	22.05	1315	22.84	1326	23.66	1336	24.49	1347	25.35	1358	26.22	1370	27.13	1395	29.01
28200	4497	1343	23.65	1352	24.45	1361	25.27	1371	26.11	1381	26.97	1392	27.84	1403	28.74	1414	29.66	1438	31.59
29200	4557	1390	26.20	1398	27.03	1408	27.87	1417	28.73	1427	29.61	1437	30.52	1447	31.44	1458	32.38	1480	34.35
30200	4816	1437	28.93	1445	29.78	1454	30.65	1463	31.53	1472	32.44	1482	33.37	1492	34.31	1502	35.28	1523	37.27

CFM	OV	3.00" SP		3.50" SP		4.00" SP		4.50" SP		5.00" SP		5.50" SP		6.00" SP		6.50" SP		7.00" SP	
		RPM	BHP	RPM	BHP	RPM	BHP	RPM	BHP	RPM	BHP	RPM	BHP	RPM	BHP	RPM	BHP	RPM	BHP
11200	1786	867	6.73	921	7.83														
12200	1945	887	7.43	938	8.56	988	9.75												
13200	2105	913	8.27	959	9.38	1006	10.59	1053	11.88	1098	13.17								
14200	2264	941	9.17	984	10.37	1027	11.56	1071	12.84	1114	14.21	1157	15.61						
15200	2424	972	10.20	1012	11.40	1053	12.69	1093	13.96	1133	15.31	1174	16.75	1215	18.24	1254	19.73		
16200	2583	1005	11.30	1043	12.59	1080	13.87	1119	15.24	1156	16.60	1194	18.00	1233	19.51	1271	21.08	1308	22.61
17200	2743	1039	12.52	1075	13.84	1111	15.22	1146	16.58	1183	18.03	1218	19.48	1254	20.94	1290	22.49	1326	24.13
18200	2902	1075	13.80	1109	15.21	1143	16.64	1177	18.09	1210	19.52	1245	21.05	1279	22.62	1312	24.12	1346	25.72
19200	3062	1111	15.18	1145	16.70	1177	18.17	1209	19.68	1241	21.21	1273	22.72	1305	24.32	1337	25.97	1369	27.56
20200	3221	1148	16.67	1181	18.25	1212	19.84	1242	21.38	1273	22.98	1304	24.59	1334	26.17	1364	27.84	1395	29.56
21200	3381	1186	18.28	1217	19.92	1248	21.58	1278	23.25	1307	24.86	1336	26.54	1365	28.23	1394	29.89	1423	31.62
22200	3540	1224	20.04	1255	21.71	1284	23.43	1314	25.18	1341	26.92	1369	28.61	1397	30.36	1425	32.14	1453	33.89
23200	3700	1262	21.93	1293	23.64	1321	25.41	1350	27.22	1378	29.05	1404	30.86	1430	32.63	1457	34.46	1484	36.32
24200	3859	1301	23.95	1330	25.73	1359	27.53	1386	29.40	1414	31.29	1440	33.20	1465	35.08	1491	36.92	1516	38.83
25200	4019	1341	26.13	1369	27.96	1397	29.82	1424	31.71	1450	33.67	1476	35.64	1501	37.63	1525	39.59	1550	41.51
26200	4178	1381	28.47	1408	30.33	1435	32.26	1462	34.19	1487	36.19	1512	38.22	1537	40.28	1562	42.35		
27200	4338	1421	30.93	1448	32.87	1474	34.84	1499	36.85	1525	38.87	1549	40.96						
28200	4497	1462	33.56	1488	35.60	1513	37.60	1538	39.66	1563	41.75								
29200	4557	1503	36.37	1528	38.45	1552	40.53												
30200	4816	1546	39.36																

CFM	OV	7.50" SP		8.00" SP		8.50" SP		9.00" SP		10.00" SP		11.00" SP		12.00" SP		13.00" SP		14.00" SP	
		RPM	BHP	RPM	BHP	RPM	BHP	RPM	BHP	RPM	BHP	RPM	BHP	RPM	BHP	RPM	BHP	RPM	BHP
16200	2583	1345	24.24																
17200	2743	1362	25.81	1397	27.50	1431	29.16												
18200	2902	1380	27.41	1414	29.16	1448	30.94	1481	32.73										
19200	3062	1401	29.20	1433	30.93	1465	32.74	1498	34.60	1561	38.37								
20200	3221	1426	31.28	1456	32.95	1486	34.72	1517	36.56										
21200	3381	1452	33.41	1481	35.23	1510	36.98	1539	38.77										
22200	3540	1480	35.65	1508	37.51	1536	39.41												
23200	3700	1511	38.15	1536	39.97	1563	41.89												
24200	3859	1542	40.77																

1. Bold figures indicate points of maximum static efficiency.
2. Performance ratings do not include effects of appurtenances in the airstream.
3. Performance shown is for installation type D: Ducted inlet, Ducted outlet.
4. Power rating (BHP) does not include drive losses.

OV - Performance Data

Omnivent - Class I & II

365

Wheel Diameter = 36.500 in.	Tip Speed, FPM = 9.56 x RPM
Outlet Area = 7.660 sq. ft.	Maximum BHP = 18.3 x (RPM/1000) ³

Maximum RPM = 1046 (Class I)
Maximum RPM = 1413 (Class II)

CFM	OV	0.25" SP		0.50" SP		0.75" SP		1.00" SP		1.25" SP		1.50" SP		1.75" SP		2.00" SP		2.50" SP	
		RPM	BHP	RPM	BHP	RPM	BHP	RPM	BHP	RPM	BHP	RPM	BHP	RPM	BHP	RPM	BHP	RPM	BHP
7600	992	313	0.55	358	0.83	403	1.14	444	1.47										
8800	1148	349	0.75	388	1.06	428	1.40	466	1.76	501	2.14								
10000	1305	387	1.00	421	1.35	455	1.71	490	2.11	524	2.51	555	2.94	588	3.39				
11200	1462	425	1.31	456	1.70	486	2.09	517	2.50	549	2.95	578	3.40	608	3.88	635	4.36		
12400	1618	463	1.68	492	2.11	520	2.55	547	2.99	575	3.44	604	3.94	631	4.44	658	4.96	707	6.02
13600	1775	503	2.12	530	2.59	555	3.07	580	3.54	605	4.03	630	4.53	656	5.08	682	5.62	730	6.76
14800	1932	542	2.63	567	3.15	591	3.67	615	4.19	637	4.70	660	5.24	684	5.78	707	6.37	754	7.56
16000	2088	582	3.24	606	3.79	628	4.35	650	4.92	671	5.48	692	6.03	714	6.62	735	7.19	779	8.47
17200	2245	622	3.93	644	4.52	666	5.12	686	5.73	706	6.34	726	6.93	745	7.54	765	8.16	806	9.44
18400	2402	663	4.72	684	5.35	704	5.99	723	6.64	745	7.29	761	7.94	779	8.57	797	9.22	834	10.55
19600	2558	703	5.62	723	6.28	742	6.96	761	7.66	778	8.34	796	9.04	814	9.73	831	10.40	865	11.80
20800	2715	744	6.63	76	7.33	781	8.08	798	8.78	816	9.51	832	10.24	849	10.98	865	11.71	898	13.15
22000	2872	785	7.76	802	8.49	820	9.25	836	10.02	853	10.80	869	11.57	885	12.34	901	13.12	931	14.64
23200	3028	826	9.01	843	9.78	859	10.58	875	11.38	891	12.20	906	13.02	921	13.83	936	14.65	966	16.29
24400	3185	867	10.39	883	11.21	898	12.04	914	12.88	929	13.74	944	14.60	958	15.46	973	16.31	1001	18.04
25600	3342	908	11.92	923	12.77	938	13.64	953	14.52	967	15.41	982	16.31	996	17.22	1010	18.12	1037	19.92
26800	3498	949	13.59	964	14.48	978	15.38	992	16.30	1006	17.23	1020	18.17	1033	19.12	1047	20.07	1073	21.95
28000	3655	991	15.42	1004	16.34	1018	17.28	1032	18.24	1045	19.21	1058	20.18	1071	21.17	1084	22.16	1110	24.13
29200	3812	1032	17.40	1045	18.36	1058	19.34	1071	20.34	1084	21.34	1097	22.36	1110	23.38	1122	24.41	1147	26.47
30400	3968	1073	19.55	1086	20.55	1099	21.57	1111	22.60	1124	23.64	1136	24.69	1148	25.75	1160	26.82	1184	28.97
31600	4125	1115	21.88	1127	22.92	1139	23.97	1151	25.04	1163	26.11	1175	27.20	1187	28.30	1199	29.41	1222	31.64
32800	4281	1156	24.38	1168	25.46	1179	26.55	1191	27.65	1203	28.77	1214	29.90	1226	31.03	1237	32.18	1259	34.48
34000	4438	1197	27.08	1209	28.19	1220	29.32	1231	30.46	1243	31.61	1254	32.78	1265	33.95	1276	35.13	1298	37.51
35200	4595	1239	29.96	1250	31.11	1261	32.28	1272	33.46	1283	34.65	1293	35.85	1304	37.06	1315	38.28	1336	40.74
36400	4751	1280	33.05	1291	34.24	1302	35.44	1312	36.66	1323	37.89	1333	39.12	1344	40.37	1354	41.63	1374	44.16
37600	4908	1322	36.35	1332	37.57	1342	38.81	1353	40.07	1363	41.33	1373	42.61	1383	43.89	1393	45.19		

CFM	OV	3.00" SP		3.50" SP		4.00" SP		4.50" SP		5.00" SP		5.50" SP		6.00" SP		6.50" SP		7.00" SP	
		RPM	BHP	RPM	BHP	RPM	BHP	RPM	BHP	RPM	BHP	RPM	BHP	RPM	BHP	RPM	BHP	RPM	BHP
13600	1775	775	7.93																
14800	1932	798	8.82	839	10.07	883	11.46												
16000	2088	821	9.76	863	11.12	900	12.47	940	13.94										
17200	2245	847	10.84	885	12.22	924	13.69	959	15.12	995	16.67								
18400	2402	873	11.97	911	13.47	947	14.94	983	16.51	1017	18.05	1049	19.66	1084	21.38				
19600	2558	900	13.22	936	14.77	972	16.36	1006	17.93	1040	19.60	1073	21.27	1103	22.91	1135	24.70	1168	26.56
20800	2715	931	14.66	964	16.19	998	17.84	1031	19.54	1063	21.20	1095	22.96	1127	24.74	1156	26.45	1185	28.29
22000	2872	962	16.21	993	17.81	1025	19.45	1057	21.20	1089	23.01	1119	24.74	1149	26.59	1179	28.48	1208	30.33
23200	3028	995	17.88	1024	19.56	1054	21.24	1084	23.00	1114	24.85	1145	26.76	1173	28.58	1202	30.50	1231	32.49
24400	3185	1029	19.73	1056	21.44	1084	23.21	1112	24.97	1141	26.84	1170	28.79	1199	30.79	1226	32.71	1254	34.70
25600	3342	1063	21.73	1089	23.48	1116	25.30	1143	27.17	1169	29.00	1197	30.98	1225	33.02	1252	35.11	1279	37.16
26800	3498	1099	23.85	1124	25.71	1149	27.56	1174	29.48	1200	31.44	1225	33.35	1252	35.43	1278	37.56	1304	39.74
28000	3655	1134	26.10	1159	28.09	1183	30.00	1207	31.96	1231	33.98	1256	36.03	1280	38.02	1305	40.19	1330	42.41
29200	3812	1170	28.52	1194	30.59	1217	32.64	1240	34.62	1264	36.69	1287	38.81	1311	40.94	1334	43.02	1358	45.27
30400	3968	1207	31.11	1230	33.25	1253	35.41	1275	37.51	1297	39.59	1319	41.75	1342	43.96	1364	46.18	1386	48.35
31600	4125	1244	33.87	1266	36.08	1288	38.33	1310	40.56	1331	42.71	1359	44.90	1374	47.19	1395	49.46		
32800	4281	1281	36.80	1303	39.10	1324	41.42	1345	43.75	1366	46.05	1386	48.27	1406	50.55				
34000	4438	1319	39.92	1340	42.32	1360	44.70	1381	47.11	1401	49.52								
35200	4595	1357	43.22	1377	45.71	1397	48.18												
36400	4751	1395	46.72																

CFM	OV	7.50" SP		8.00" SP		8.50" SP		9.00" SP		10.00" SP		11.00" SP		12.00" SP		13.00" SP		14.00" SP	
		RPM	BHP	RPM	BHP	RPM	BHP	RPM	BHP	RPM	BHP	RPM	BHP	RPM	BHP	RPM	BHP	RPM	BHP
22000	2872	1235	32.17	1263	34.16	1292	36.22												
23200	3028	1258	34.47	1285	36.37	1310	38.39	1337	40.50										
24400	3185	1281	36.77	1308	38.87	1334	40.93	1358	42.94	1409	47.32								
25600	3342	1304	39.21	1331	41.35	1357	43.54	1382	45.74										
26800	3498	1330	41.92	1355	44.03	1380	46.23	1405	48.51										
28000	3655	1356	44.67	1381	46.99	1404	49.17												
29200	3812	1382	47.57	1406	49.92														
30400	3968	1410	50.67																

1. Bold figures indicate points of maximum static efficiency.
2. Performance ratings do not include effects of appurtenances in the airstream.
3. Performance shown is for installation type D: Ducted inlet, Ducted outlet.
4. Power rating (BHP) does not include drive losses.

Vent Set Dimensions - SWSI

Omnivent - OV

90-300

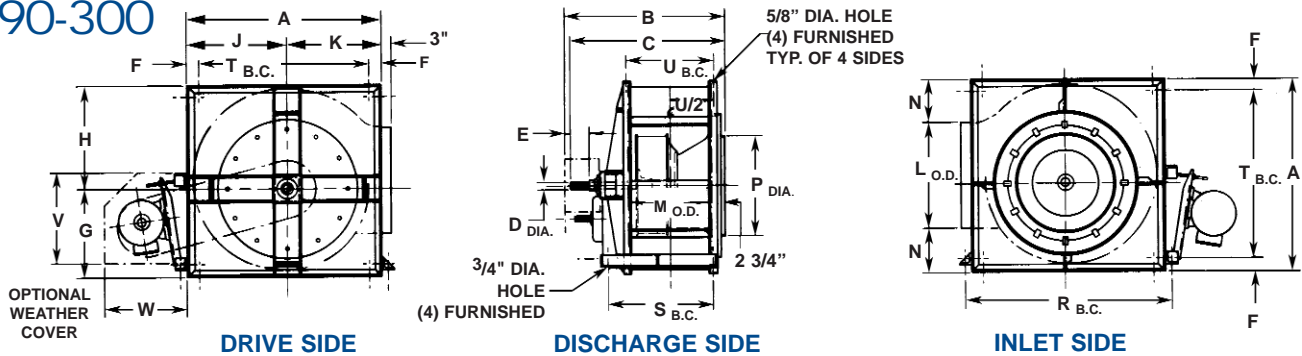

Fan Size	Motor Fr. Range	A	B	C	D	SQ. KEY	E	F	G	H	J	K
90	48-145T	17-3/4	17-3/4	18-1/8	3/4	3/16	3	1-7/16	7-1/8	9-7/8	9	8-3/4
105	48-145T	20-5/8	20-1/4	20-5/8	3/4	3/16	3	1-7/16	9-1/8	11-1/2	10-1/2	10-1/8
122	56-184T	24-1/8	21-1/8	20-15/16	1-3/16	1/4	3-1/8	1-7/16	10-5/8	13-1/2	12-1/4	11-7/8
135	56-184T	26-1/8	22-1/8	21-15/16	1-3/16	1/4	3-1/8	1-7/16	11-3/8	14-3/4	13-5/16	12-13/16
150	56-184T	28-5/8	23-1/4	23-1/16	1-3/16	1/4	3-1/8	1-7/16	12-11/16	15-15/16	14-11/16	13-15/16
165	56-184T	31-5/8	24-1/2	24-5/16	1-3/16	1/4	3-1/8	1-7/16	13-15/16	17-11/16	16-1/16	15-9/16
182	56-184T	34-7/8	25-3/4	25-9/16	1-3/16	1/4	3-1/8	1-7/16	15-3/16	19-11/16	17-13/16	17-1/16
200	56-215T	38-1/8	28-1/4	28-1/16	1-3/16	1/4	3-1/8	1-3/4	16-9/16	21-9/16	19-9/16	18-9/16
222	56-215T	42-1/8	31-3/4	30-1/16	1-7/16	1/4	3-1/8	1-3/4	18-7/16	23-11/16	21-9/16	20-9/16
245	56-215T	46-3/8	33-1/2	32-1/16	1-7/16	1/4	3-1/8	1-3/4	20-3/16	26-3/16	23-11/16	22-11/16
270	56-215T	50-5/8	35-1/2	34-1/16	1-7/16	1/4	3-1/8	1-3/4	22-1/8	28-1/2	25-15/16	24-11/16
300	56-256T	56-5/8	39	37-7/16	1-11/16	1/4	3-1/8	1-3/4	24-9/16	32-1/16	28-13/16	27-13/16

Fan Size	Motor Fr. Range	L	M	N	P	R	S	T	U	V	W	APPROX. WEIGHT*
90	48-145T	10	6-11/16	3-7/8	8	19-1/2	10-3/4	14-7/8	7-11/16	12-7/8	12	75
105	48-145T	12	9-3/16	4-5/16	9	22-3/8	13-1/4	17-3/4	10-3/16	15	12	95
122	56-184T	13	9-7/8	5-9/16	12-7/8	26-3/8	13-3/4	21-1/4	11-7/8	15	16	140
135	56-184T	14-5/16	10-7/8	5-29/32	14-1/2	28-3/8	14-3/4	23-1/4	12-7/8	15	16	155
150	56-184T	15-7/8	12	6-3/8	16-1/4	30-7/8	15-7/8	25-3/4	14	15	16	190
165	56-184T	17-7/16	13-1/4	7-3/32	17-7/8	33-7/8	17-1/8	28-3/4	15-1/4	15	16	220
182	56-184T	19-5/16	14-5/8	7-25/32	19-3/4	37-1/8	18-3/8	32	16-1/2	15	16	240
200	56-215T	21-1/8	16	8-1/2	21-5/8	41	21	34-5/8	18	17	21-1/2	310
222	56-215T	23-1/2	17-3/4	9-5/16	24	45	23-1/4	38-5/8	19-3/4	17	21-1/2	350
245	56-215T	26	19-5/8	10-3/16	26-3/8	49-1/4	25	42-7/8	21-1/2	17	21-1/2	410
270	56-215T	28-9/16	21-1/2	11-1/32	29	53-1/2	27	47-1/8	23-1/2	17	21-1/2	500
300	56-256T	31-3/4	23-7/8	12-7/16	32-3/8	59-1/2	30-3/4	53-1/8	25-3/4	17	21-1/2	620

330-365

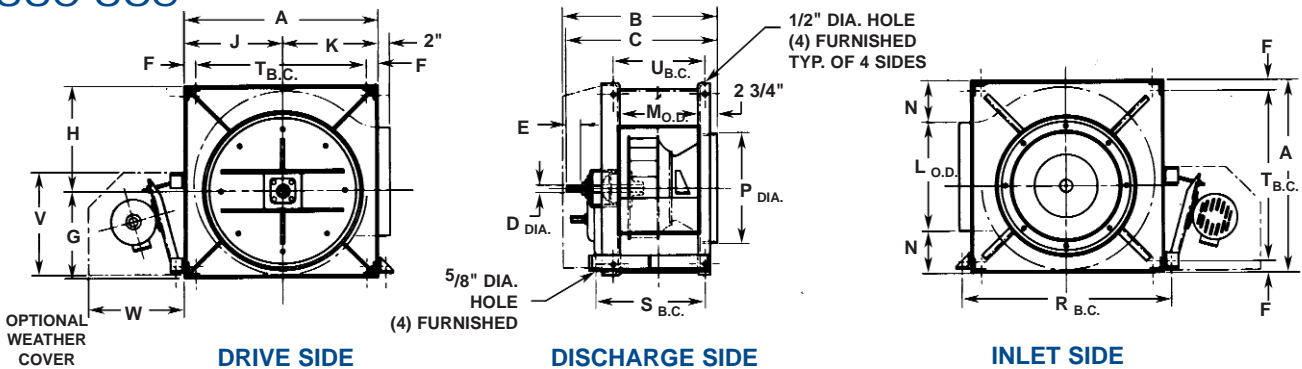

Fan Size	Motor Fr. Range	A	B	C	D CL.1	SQ. KEY	D CL.2	SQ. KEY	E	F	G	H	J
330	56-326T	63	50-7/16	48-7/16	1-15/16	1/2	2-3/16	1/2	6	3	28	35	31-5/8
365	56-326T	69-1/2	53-3/16	51-3/16	1-15/16	1/2	2-7/16	5/8	6	3	30-13/16	38-11/16	34-15/16

Fan Size	Motor Fr. Range	K	L	M	N	P	R	S	T	U	V	W	APPROX. WEIGHT*
330	56-326T	31-3/8	34-7/8	26-1/4	14-1/16	35-1/2	67	34-5/8	57	28-5/8	33	30	950
365	56-326T	34-9/16	38-9/16	29	15-15/32	39-1/4	73-1/2	37-5/8	63-1/2	31-3/8	33	30	1200

* Weight in LBS. Weights are less Motor and Drives.

GENERAL 1.0

- 1.1 Fans shall be tested and rated in accordance with AMCA 210 standard and bear the AMCA certified rating seal.
- 1.2 Fans shall meet AMCA 99 Standards
- 1.3 All motors and electrical components shall comply to NEMA, UL or other governing group.

PRODUCT 2.0

- 2.1 Fan shall be of centrifugal type configuration with a backward inclined impeller.
- 2.2 Fan shall be belt drive configuration with a 1.5 drive service factor.
- 2.3 Fan housing shall be of continuous welded construction and shall be constructed completely of carbon steel and shall have square flanged side panel offering a rigid fan structure.
 - 2.3.1 The fan housing shall have the discharge centered in side panels and the drive rotor assembly shall be removable for inspection of maintenance while the fan assembly remains with the inlet and outlet duct connected.
 - 2.3.2 The fan housing shall allow for mounting of the motor in four possible positions on the fan housing on a floor mounted fan assembly and six possible positions on a suspended fan assembly.
 - 2.3.3 The fan housing shall offer four possible discharge positions and due to its center discharge characteristic eliminating the need to specify clockwise or counter-clock wise rotation designation.
 - 2.3.4 Due to characteristic of fan the housing discharge position shall be field changeable (four positions).
- 2.4 The motor shall be mounted on a steel formed frame and have a parallel pivot adjustment ability.
- 2.5 Due to characteristic of fan, the motor position shall be field changeable (four to six positions).
- 2.6 The fan shall incorporate a full class 1 performance capability impeller wheel.
 - 2.6.1 Impeller shall produce an operation curve that meets AMCA 99 operating limits for class one fans.
 - 2.6.2 Fan wheel and cone assembly shall be concentric and overlap allowing for enhanced pressure ability.
- 2.7 Fan shaft shall be C1045, T, G, & P material and designed for operation at 20% below the shaft critical speed.
 - 2.7.1 Fan bearings shall be flanged, cast iron housing, ball type, sealed and relubricatable.
- 2.8 Fan shall be of AMCA spark resistant construction when required and as indicated on the fan schedule as either AMCA "A", "B" or "C"
- 2.9 Fan shall be coated with enamel as standard or any other available coating as made available by coating suppliers and as indicated on the fan schedule.

One Year Limited Warranty

Omnivent

What Products Are Covered

PennBarry Fans and Ventilators (each, a "PennBarry Product")

One Year Limited Warranty For PennBarry Products

PennBarry warrants to the original commercial purchaser that the PennBarry Products will be free from defects in material and workmanship for a period of one (1) year from the date of shipment.

Exclusive Remedy

PennBarry will, at its option, repair or replace (without removal or installation) the affected components of any defective PennBarry Product; repair or replace (without removal or installation) the entire defective PennBarry Product; or refund the invoice price of the PennBarry Product. In all cases, a reasonable time period must be allowed for warranty repairs to be completed.

What You Must Do

In order to make a claim under these warranties:

1. You must be the original commercial purchaser of the PennBarry Product.
2. You must promptly notify us, within the warranty period, of any defect and provide us with any substantiation that we may reasonably request.
3. The PennBarry Product must have been installed and maintained in accordance with good industry practice and any specific PennBarry recommendations.

Exclusions

These warranties do not cover defects caused by:

1. Improper design or operation of the system into which the PennBarry Product is incorporated.
2. Improper installation.
3. Accident, abuse or misuse.
4. Unreasonable use (including any use for non-commercial purposes, failure to provide reasonable and necessary maintenance as specified by PennBarry, misapplication and operation in excess of stated performance characteristics).
5. Components not manufactured by PennBarry.

Limitations

1. In all cases, PennBarry reserves the right to fully satisfy its obligations under the Limited Warranties by refunding the invoice price of the defective PennBarry Product (or, if the PennBarry Product has been discontinued, of the most nearly comparable current product).
2. PennBarry reserves the right to furnish a substitute or replacement component or product in the event a PennBarry Product or any component of the product is discontinued or otherwise unavailable.
3. PennBarry's only obligation with respect to components not manufactured by PennBarry shall be to pass through the warranty made by the manufacturer of the defective component.

General

The foregoing warranties are exclusive and in lieu of all other warranties except that of title, whether written, oral or implied, in fact or in law (including any warranty of merchantability or fitness for a particular purpose).

PennBarry hereby disclaims any liability for special, punitive, indirect, incidental or consequential damages, including without limitation lost profits or revenues, loss of use of equipment, cost of capital, cost of substitute products, facilities or services, downtime, shutdown or slowdown costs.

The remedies of the original commercial purchaser set forth herein are exclusive and the liability of PennBarry with respect to the PennBarry Products, whether in contract, tort, warranty, strict liability or other legal theory shall not exceed the invoice price charged by PennBarry to its customer for the affected PennBarry Product at the time the claim is made.

Inquiries regarding these warranties should be sent to: PennBarry, 1401 North Plano Road, Richardson, TX 75081

OTHER PENNBARRY PRODUCTS

CENTRIFUGAL PRODUCTS



Domex
Centrifugal
Roof Exhausters



Fumex Fatrap
Kitchen Hood Centrifugal
Roof Exhausters



Zephyr
Ceiling and Inline Fans

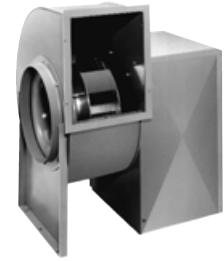

Dynamo
Centrifugal Blowers



Centrex Inliner
Centrifugal Inline Fans



LC Dynafan
Low Contour Centrifugal
Roof Exhausters



ESI
Efficient Silent
Inline Fan



Fume Exhaust
Curb Mounted
Centrifugal Fans

AXIAL / GRAVITY PRODUCTS

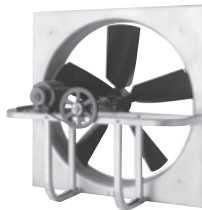

Breezeway
Propeller Wall Fans



HI-EX
Power Roof Ventilator



Tubeaxial
Inline Fans



Vaneaxial
Inline Fans

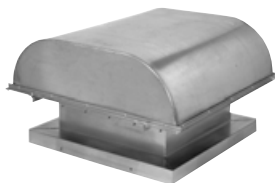

Powered Airette
Axial Roof Ventilators

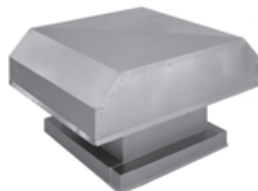

Airette
Gravity Intake/Relief Hood



Domex Axial
Axial Roof Ventilators



Axcentrix
Bifurcator Fan

For more information contact your local PennBarry Sales
Manufacturer Representative or visit us at www.PennBarry.com

